

Distance-setting Photoelectric Sensor

E3G-L1/L3

- Reliable detection of differently colored, uneven and/or glossy objects in front of defined background (e.g. conveyors).



Features

1 mm dia. pin-point beam allows detection of minute objects

(E3G-L1)

OMRON's unique Hyper LED achieves a pin-point light source only 1/7 the size of conventional light sources, with uniform light-intensity distribution. The Hyper LED achieves stable detection of small objects by eliminating non-detection of objects due to the drop-out which commonly occurs at the center of conventional LEDs.

The clearly visible spot makes it easy to check the optical axis adjustment and sensing position.

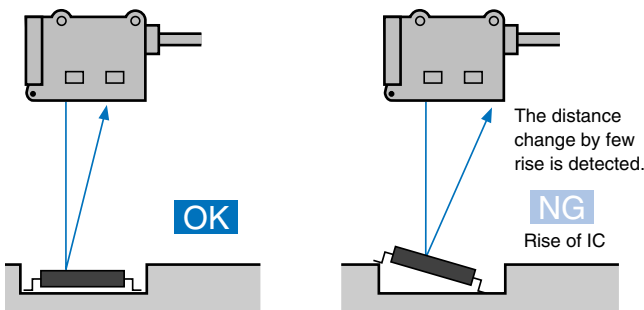

Stable detection is not limited to object color, but also on inclination and glossiness

(Inclination characteristic of E3G-L1 is 2.6 times better than that of conventional models.)

The use of the shining object free optical system with the conventional triangulation measuring reduces the discrepancies in sensing distance due to object color, surface, and inclination. (E3G-L3: 2.2 times better than conventional model)

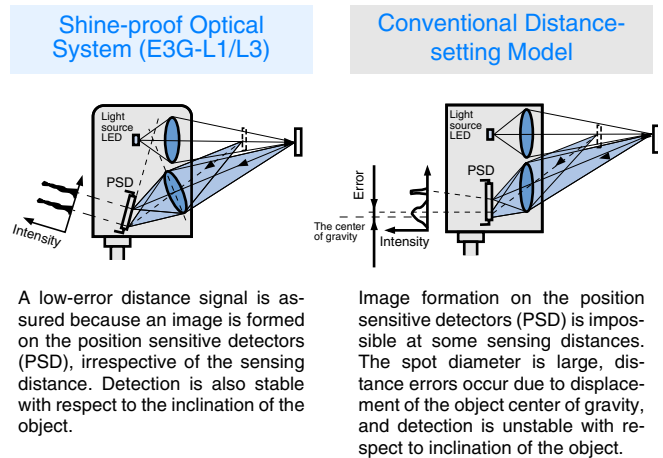

Application

Meets the needs of all industries, including semiconductors, electronic components, food and packaging

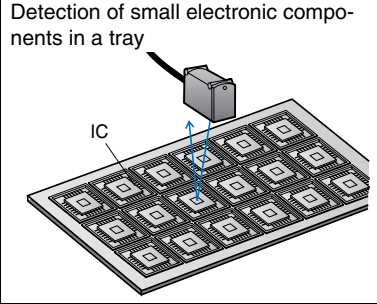
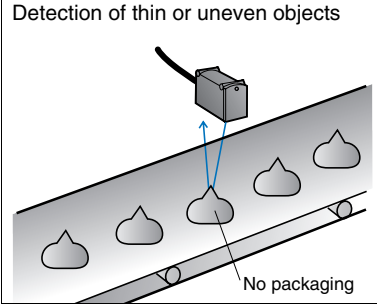
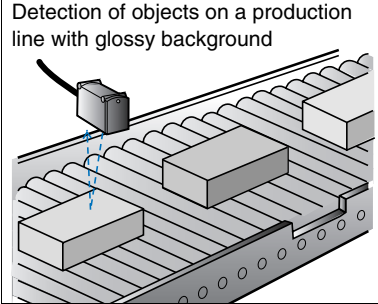
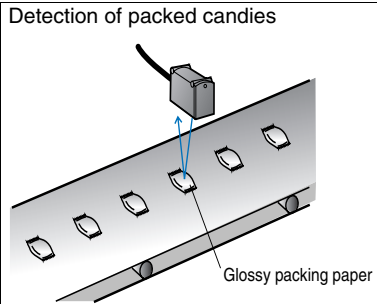
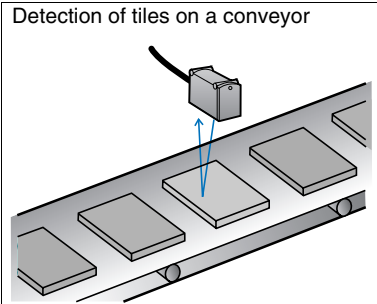
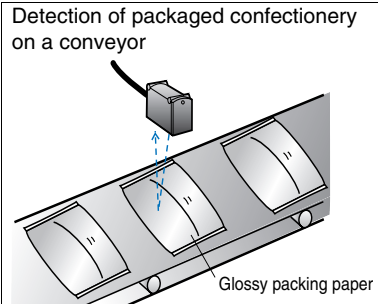
Normal mode		
<p>E3G-L1 (50 mm type)</p> <p>Detection of small electronic components in a tray</p> 	<p>Detection of thin or uneven objects</p> 	<p>E3G-L3 (200 mm type)</p> <p>Detection of objects on a production line with glossy background</p> 
Zone mode		
<p>E3G-L1 (50 mm type)</p> <p>Detection of packed candies</p> 	<p>Detection of tiles on a conveyor</p> 	<p>E3G-L3 (200 mm type)</p> <p>Detection of packaged confectionery on a conveyor</p> 

Features

Simple Detection of Glossy, Uneven Objects

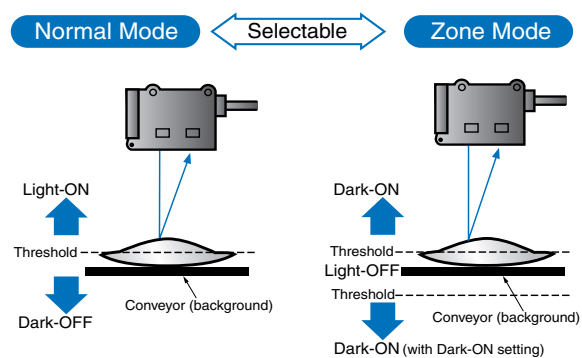

As a triangulation measuring with 4% or less differential travel (E3G-L1) is used, objects behind the setting distance cannot be detected. At a setting distance of 30 mm, a step on objects with a thickness of 1.2 mm can be detected.

Glossy, uneven objects are reliably detected because the Light-OFF status occurs only when the conveyor is detected, and Dark-ON status when objects exist.

Optimal Background and Conveyor Teaching Double-bar Display Indicates Excess Gain at a Glance

Features one-touch teaching function settings. After the object, background, and conveyor are complete, fine adjustment of the sensitivity can be made in 13 levels in the Normal mode or in 5 levels in the Zone mode. It is simple to increase excess gain and set up the fine-step detection.

The operation indicator turns ON when the light incident level exceeds a threshold value. After the object, background, and conveyor are complete, fine adjustment of the sensitivity can be made in 13 levels in the Normal mode or in 5 levels in the Zone mode. It is simple to increase excess gain and set up the fine-step detection.

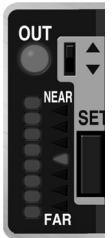
Line-up of M8 Connector Type

Easy to disconnect and maintain.

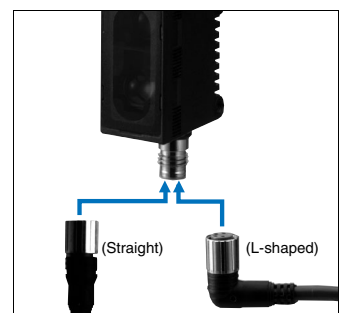

Ordering Information

Sensors

Red light Infrared light

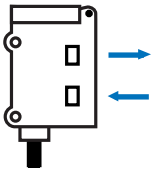
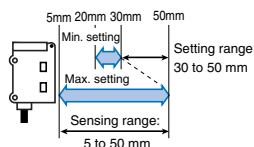
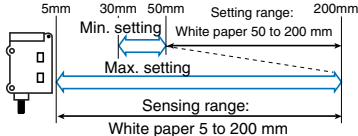

Shape	Connection method	Sensing/Setting range	Operating mode	Model	
				NPN output	PNP output
	Pre-wired		Light-ON Dark-ON (selectable)	E3G-L11	E3G-L12
	Connector type			E3G-L15	E3G-L16
	Pre-wired			E3G-L31	E3G-L32
	Connector type			E3G-L35	E3G-L36

Accessories

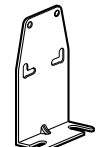
Mounting Brackets

Shape	Model	Quantity	Remarks
	E39-L139	1	Provided with E3G-L□1/-L□2
	E39-L140	1	Provided with E3G-L□5/-L□6

Sensor I/O Connectors

Cable	Shape	Cable length	Model
Standard cable		2 m	XS3F-M421-402-A
		5 m	XS3F-M421-405-A
		2 m	XS3F-M422-402-A
		5 m	XS3F-M422-405-A

Rating/Performance

Item	Sensor type		Distance-setting			
	Model	NPN output	E3G-L11	E3G-L15	E3G-L31	E3G-L35
		PNP output	E3G-L12	E3G-L16	E3G-L32	E3G-L36
Sensing	5 to 50 mm (White paper 50 x 50 mm, Setting distance 50 mm)			5 to 200 mm (White paper 50 x 50 mm, Setting distance 200 mm) 5 to 150 mm (Black paper 50 x 50 mm, Setting distance 150 mm)		
Setting range	30 to 50 mm (White paper/Black paper 50 x 50 mm)			50 to 200 mm (White paper 50 x 50 mm) 50 to 150 mm (Black paper 50 x 50 mm)		
Differential distance	4% max. of sensing distance			10% of setting distance (typical)		
Reflectivity characteristics (black/white error)	4% max. of sensing distance			10% max. of setting distance (Setting distance 50 to 150 mm)		
Light source (wave length)	Red LED (650 nm)			Infrared LED (860 nm)		
Spot size	1 mm dia. max. (Sensing distance 38 mm)			15 mm dia. max. (Sensing distance 150 mm)		
Power supply voltage	10 to 30 VDC [ripple (p-p) 10% included]					
Current consumption	55 mA max.			65 mA max.		
Control output	Load supply voltage 30 VDC max., load current 100 mA max. (residual voltage NPN type: 1.2 V max., PNP type: 2 V max.) Open collector output type (depends on the NPN/PNP output, format) Light-ON/Dark-ON switch selectable					
Protective circuits	Reverse polarity protection, output short-circuit protection, mutual interference prevention					
Response time	Operation or reset: 1.5 ms max.			Operation or reset: 2.5 ms max.		
Distance setting	Teaching method (NORMAL mode/ZONE mode)					
Fine distance adjustment	Manual threshold fine adjustment (NORMAL mode: 13 levels/ZONE mode: 5 levels)					
Indicator lamp	Operation indication (orange), distance indication (green, 8 levels), threshold indication (red, NORMAL mode: 13 levels/ZONE mode: 5 levels)					
Ambient illuminance	Incandescent lamp: 3,000 lux max. Sunlight: 10,000 lux max.					
Ambient temperature	Operating: -25°C to 55°C, Storage: -30°C to 70°C (with no icing or condensation)					
Ambient humidity	Operating: 35% to 85%RH, Storage: 35% to 95%RH (with no condensation)					
Insulation resistance	20 M Ω min. at 500 VDC					
Dielectric strength	1,000 VAC at 50/60 Hz for 1 minute					
Vibration resistance	10 to 55 Hz, 1.5 mm double amplitude for 2 hours each in X, Y, and Z directions					
Shock resistance	Destruction: 500 m/s ² for 3 times each in X, Y, and Z directions					
Protective structure	IEC 60529 IP67 (with Protective Cover attached)					
Connection method	Pre-wired (standard length: 2 m)	M8 connector	Pre-wired (standard length: 2 m)	M8 connector		
Weight (Packed state)	Approx. 64 g	Approx. 21 g	Approx. 64 g	Approx. 21 g		
Material	Case	PBT (polybutylene terephthalate)				
	Cover	Acrylics (PMMA)				
	Mounting Brackets	Stainless steel (SUS304)				
Accessories	Mounting bracket (with screws), instruction manual					

Characteristic data (typical)

Close-range Characteristics

E3G-L1□

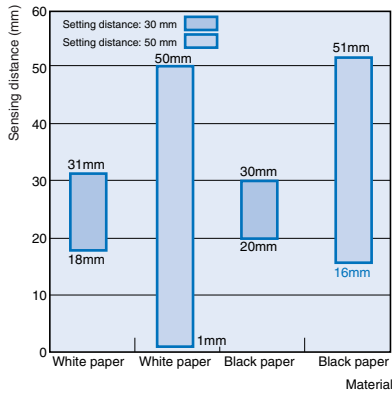

E3G-L3□

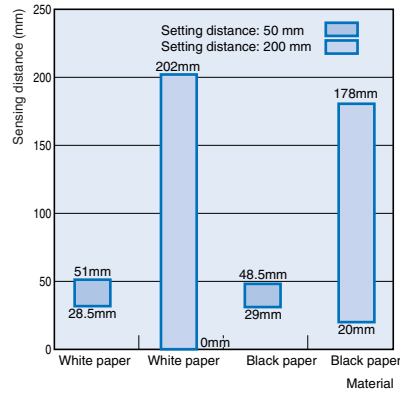

Part names and functions

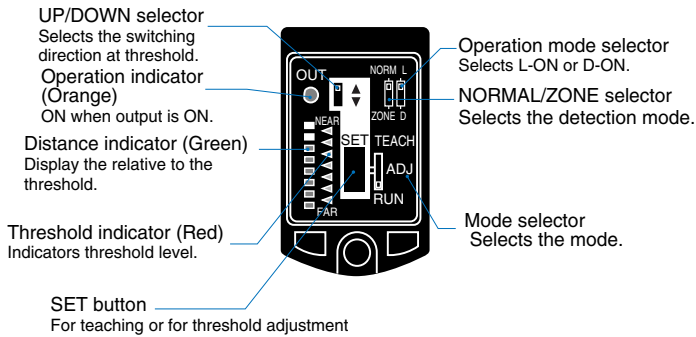

Output Circuit Diagram

NPN output

Model	Operating status of output transistor	Timing chart	Mode selection switch	Output circuit
E3G-L11 E3G-L15 E3G-L31 E3G-L35	Light ON		L ON (LIGHT ON)	
	Dark ON		D ON (DARK ON)	

PNP output

Model	Operating status of output transistor	Timing chart	Mode selection switch	Output circuit
E3G-L12 E3G-L16 E3G-L32 E3G-L36	Light ON		L ON (LIGHT ON)	
	Dark ON		D ON (DARK ON)	

Connectors (Sensor I/O connectors)

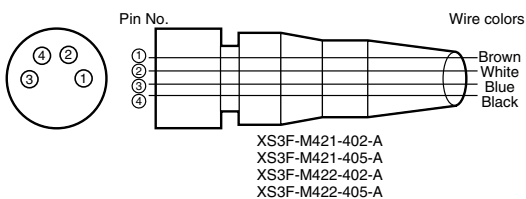

Class	Wire, outer jacket color	Connector pin No.	Application
For DC	Brown	1	Power supply (+V)
	White	2	---
	Blue	3	Power supply (0 V)
	Black	4	Output

Note: Pin 2 is open.

Operation

Adjustment Steps

Procedure	Operation
1	Install, wire, and turn on the Sensor.
2	Perform distance setting (teaching). Refer to "Distance Setting (Teaching)".
3	Fine-adjust the threshold as necessary. Refer to "Manual Tuning (Fine Distance Adjustment)" on page A-194.
4	Check that the mode selector is set to RUN .

Distance Setting (Teaching)

Select the most appropriate teaching method in reference to the following descriptions.

Application	1	2	3
	<ul style="list-style-type: none"> Teaching without sensing objects (i.e. Teaching the background). 	<ul style="list-style-type: none"> Detection of slight differences in surface level. Setting a threshold in the middle between the background and sensing object for operation. 	<ul style="list-style-type: none"> Detection of glossy objects in front of the background.

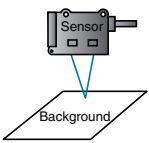
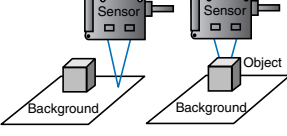
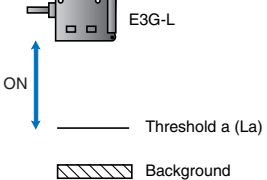
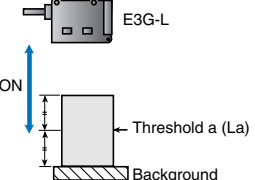
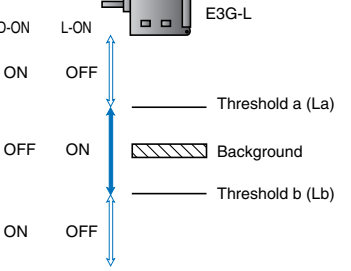

Teaching	1	2	3
	Normal one-point teaching	Normal two-point teaching	Zone one-point teaching
Setting method	Press the TEACH button with the background object. 	Press the TEACH button with background object and with sensing object. 	Press the TEACH button with the background object (conveyor, etc.).
Set threshold	Threshold (a) is set immediately in front of the background.	Threshold (a) is set approximately in the middle between the background and sensing object.	A pair of thresholds, (a) and (b), are set.
Output ON range	The output is ON between the Sensor and La. 	The output is ON between the Sensor and La. 	The output is ON between La and Lb. 

La: Distance equivalent to threshold (a) Lb: Distance equivalent to threshold (b)

- The following settings are also possible:
 - Setting the maximum sensing distance of the Sensor: Maximum distance setting.
 - Setting the minimum differential travel of the Sensor: Minimum distance setting.
- Distance from sensor to background must be as shown below during normal one-point or zone one-point teaching.

Model	Distance from sensor to background
E3G-L1□	32 mm min.
E3G-L3□	55 mm min.

- Maximum sensing distance of E3G-L3 type may differ by color of the sensing object when setting distance is more than 150 mm. Confirm the operation of the Sensor before actual operation.

1 Normal one-point teaching

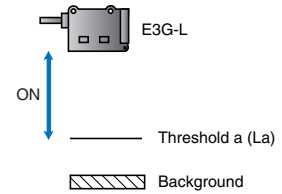
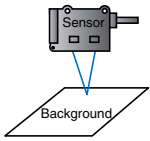

Pro- ce- dure	Operation	Panel Status
1	Set the mode selector to TEACH .	
2	Set the NORMAL/ZONE mode selector to NORMAL .	
3	Press the SET button with the background. • All threshold indicators (red) are turned ON.	
4	Set the mode selector to RUN .	
5	Set to L-ON or D-ON mode with the operation mode selector. L-ON: Output ON between background and sensor. D-ON: Output OFF between background and sensor.	
Application Example 1		
1	Set the mode selector to TEACH .	
2	Set the NORMAL/ZONE mode selector to NORMAL .	
3	Set the UP/DOWN selector to down.	
4	Press the SET button for 3 s or more. • All threshold indicators (red) are turned ON.	
5	When all distance indicators (green) are then turned ON, the setting is complete. Set the mode selector to RUN .	
6	Set L-ON/D-ON with the operation mode selector. (Refer to Normal one-point teaching)	
Application Example 2		
1	Set the mode selector to TEACH .	
2	Set the NORMAL/ZONE mode selector to NORMAL .	
3	Set the UP/DOWN selector to up.	
4	Press the SET button for 3 s or more. • All threshold indicators (red) are turned ON.	
5	When all distance indicators (green) are turned ON, the setting is complete. Set the mode selector to RUN .	
6	Set L-ON/D-ON with the operation mode selector. (Refer to Normal one-point teaching)	

La: Distance equivalent to threshold (a)

2 Normal two-point teaching

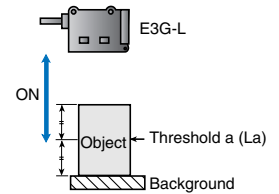
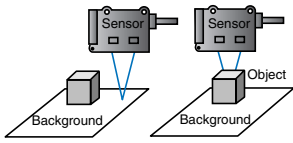

Proce-dure	Operation	Panel Status
1	Set the mode selector to TEACH .	<p>Object</p> <p>Threshold indicator (red) turns ON.</p> <p>Background</p> <p>Distance indicator (green) turns ON.</p> <p>Threshold indicator (red) starts to flash.</p>
2	Set the NORMAL/ZONE mode selector to NORMAL .	
3	Press the SET button with a sensing object located at sensing position. • All threshold indicators (red) are turned ON.	
4	Move the sensing object and press the SET button with the back-ground. • If the teaching is successful, all distance indicators (green) are turned ON. • If the teaching is not successful, all threshold indicators (red) flicker.	
5	If the teaching is successful, set the mode selector to RUN to complete the teaching operation. If the teaching is not successful, change the position of the object and setting distance that have been set and repeat from the above step 3.	
6	Set to L-ON or D-ON mode with the operation mode selector.	

La: Distance equivalent to threshold (a)

3 Zone one-point teaching

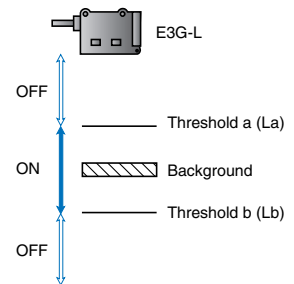
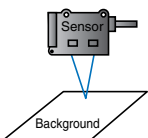

Proce-dure	Operation	Panel Status
1	Set the mode selector to TEACH .	<p>Distance indicator (green) turns ON.</p> <p>Threshold indicator (red) starts to flash.</p>
2	Set the NORMAL/ZONE mode selector to ZONE .	
3	Press the SET button with the background. While the button is pressed, all threshold indicators (red) are turned ON. When the button is released: • If the teaching is successful, all distance indicators (green) are turned ON.	
4	Set the mode selector to RUN .	
5	Set to L-ON or D-ON mode with the operation mode selector. L-ON: Output ON between background and sensor. D-ON: Output OFF between background and sensor.	

La: Distance equivalent to threshold (a)

Precautions

Correct Use

Wiring Considerations

Cable

The bending radius should be 25 mm or more.

Avoiding Malfunctions

If using the photoelectric sensor with an inverter or servomotor, be sure to ground the FG (frame ground) and G (ground) terminals, otherwise the Sensor may malfunction.

Mounting

Mounting the Sensor

- If Sensors are mounted face-to-face, ensure that no optical axes cross each other. Otherwise, mutual interference may result.
- Be sure to install the Sensor carefully so that the directional angle range of the Sensor will not be directly exposed to intensive light, such as sunlight, fluorescent light, or incandescent light.
- Do not strike the Photoelectric Sensor with a hammer or any other tool during the installation of the Sensor, or the Sensor will lose its water-resistant properties.
- Use M3 screws to mount the Sensor.
- When mounting the case, make sure that the tightening torque applied to each screw does not exceed 0.54 Nm.

M8 Connector

- Be sure to connect or disconnect the metal connector after turning OFF the Sensor.
- Hold the connector cover to connect or disconnect the metal connector.
- Secure the connector cover by hand. Do not use any pliers, otherwise the connector may be damaged.
- If the M8 connector is not connected securely, the M8 connector may be disconnected by vibration or the proper degree of protection of the Sensor may not be maintained.

Installation Directions

- Ensure that the sensing side of the Sensor is parallel to the surface of each sensing object. Do not incline the Sensor towards the sensing object.

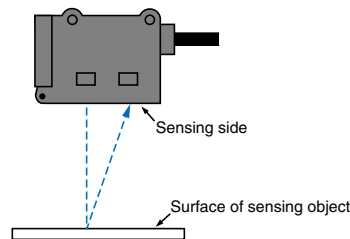

If the sensing object has a glossy surface, incline the Sensor by 5° to 10° as shown on the right, provided that the Sensor is not influenced by any background objects.

- If there is a mirror-like object below the Sensor, the Sensor may not be in stable operation. Therefore, incline the Sensor or keep the Sensor at a certain distance from the mirror-like object as shown below.

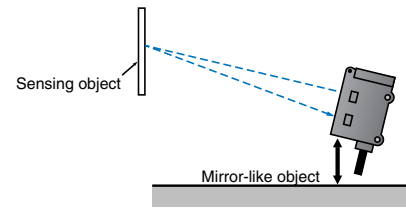
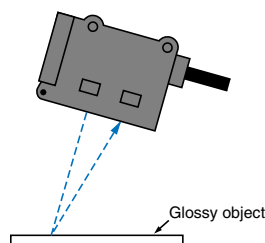

- Ensure not to install the Sensor in the incorrect direction. Refer to the following.

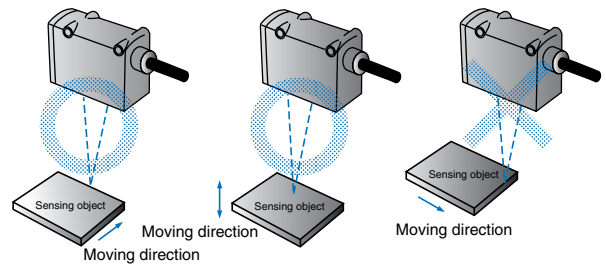

Install the Sensor as shown in the following if each sensing object greatly differs in color or material.

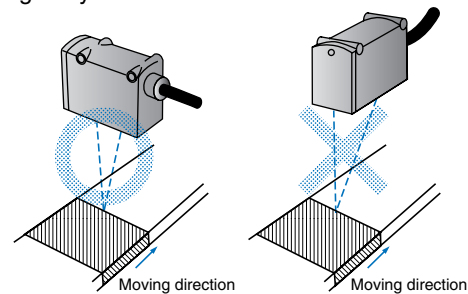

● Adjustment

If the Sensor is not in stable operation due to color differences, perform a fine adjustment of the threshold level and confirm stable detection. Refer to "Manual Teaching (Fine Distance Setting).

● Maintenance and Inspection

Cleaning

Thinner or like damage the casing of the Sensor. Do not apply thinner to clean the Sensor.

Miscellaneous

EEPROM Writing Error

If a teaching data error occurs (with the operation indicator flashing) due to a power failure or static noise, perform the teaching operation of the Sensor again.

Water Resistance

To ensure the water resistivity of the Sensor, tighten the screws of the operation panel cover to a torque of 0.2 to 0.3 Nm.

Dimensions (Unit: mm)

Sensors

Pre-wired

E3G-L11/L31
E3G-L12/L32

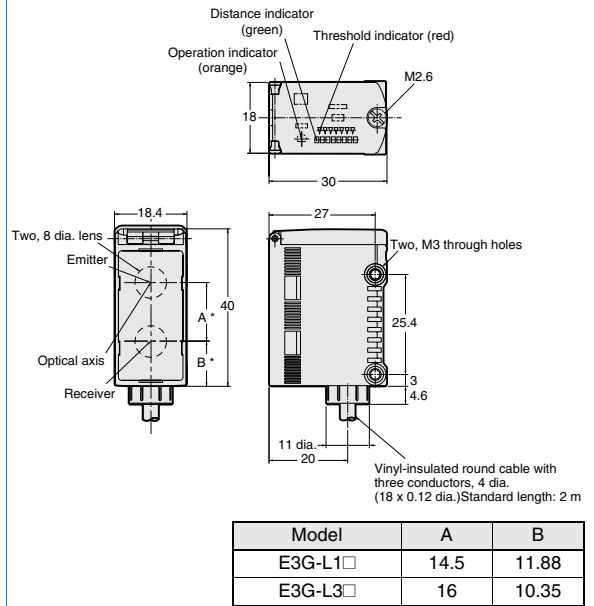
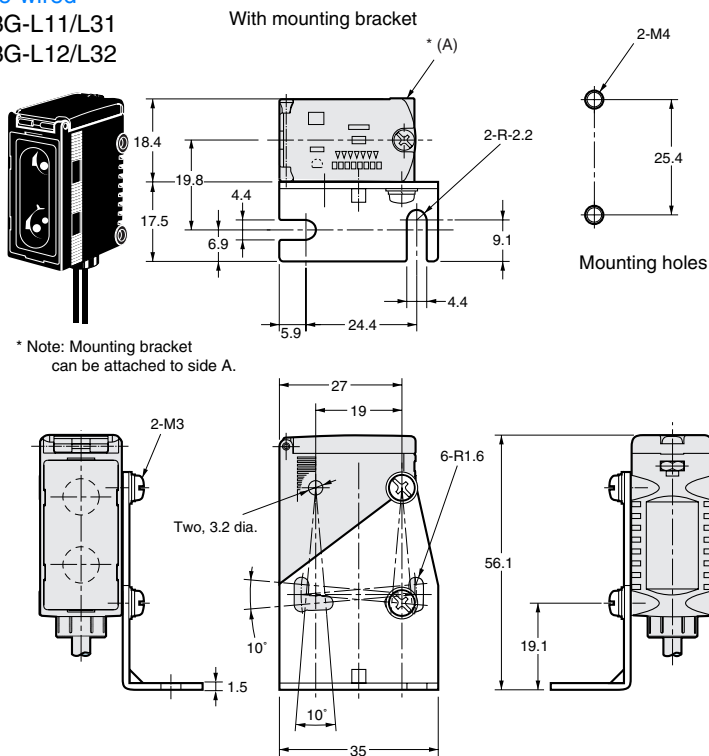

Connector type

E3G-L15/L35
E3G-L16/L36

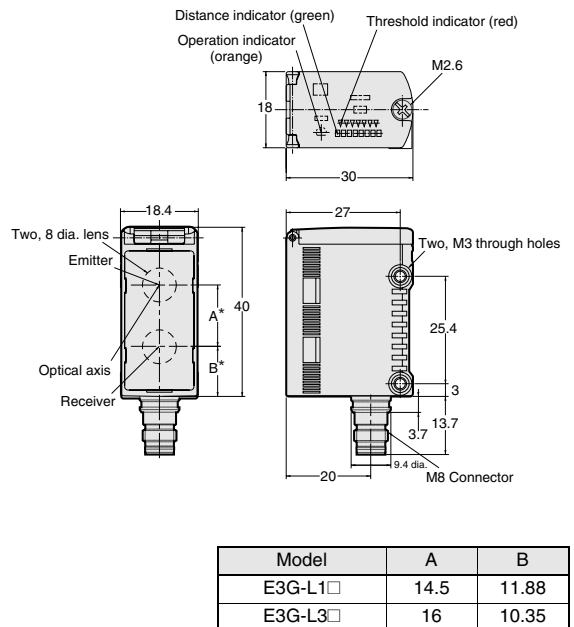
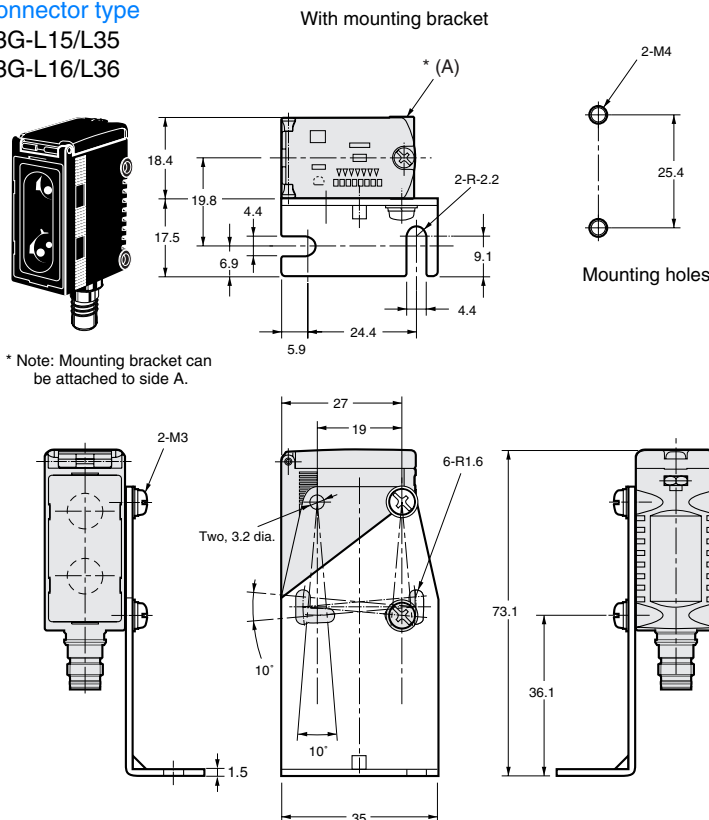

Accessories (Order Separately)

A-215

ALL DIMENSIONS SHOWN ARE IN MILLIMETERS.
To convert millimeters into inches, multiply by 0.03937. To convert grams into ounces, multiply by 0.03527.