

PF105214



Application: conveying

### Presentation

The Altivar 31C drive is a frequency inverter for three-phase 200...500 V asynchronous motors rated from 0.18 kW to 15 kW.

The enclosed Altivar 31C offer with its rugged design, compact size and integrated functions is specifically adapted to respond to numerous applications requiring an IP 55 degree of protection in a hostile environment.

These characteristics also offer the possibility of installing the Altivar 31C drive as close to the motor as possible.

Examples of solutions provided:

- IP 55 drive offering a remote solution which can be customized depending on the model
- Drive integrating the Modbus and CANopen communication protocols
- Numerous options for loading, printing and saving drive configurations using the remote display terminal, SoMove setup software and the Simple Loader configuration tool

### Applications

The Altivar 31C drive incorporates functions that are suitable for numerous applications, including:

- Material handling (conveyors, hoists, etc.)
- Packing and packaging machines (labelling machines, sack filling machines, etc.)
- Pumping applications (suction pumps, centrifugal pumps, circulating pumps, mono-pump and multi-pump stations, etc.)
- Machines equipped with fans (air or smoke extraction, plastic film making machines, ovens, boilers, washing machines, etc.)
- Specialist machines (mixers, kneaders, textile machines, etc.)

PF600160



Application: ventilation

### Functions

The Altivar 31C drive has six logic inputs, three analog inputs, one logic/analog output and two relay outputs.

Main integrated functions:

- Motor and drive protection
- Linear, S, U or customized acceleration and deceleration ramps
- +/- speed
- 16 preset speeds
- PI regulator and references
- 2-wire/3-wire control
- Brake sequence
- Automatic catching a spinning load with speed detection and automatic restart
- Fault configuration and stop type configuration
- Saving the configuration in the drive

Several functions can be assigned to one logic input.

### A optimized offer

The Altivar 31C range of variable speed drives covers motor power ratings from 0.18 kW to 15 kW with two types of power supply:

- 200 V to 240 V single-phase 0.18 kW to 2.2 kW: **ATV 31C●●●M2**
- 380 V to 500 V three-phase 0.37 kW to 15 kW: **ATV 31C●●●N4**

Available in 200...240 V single-phase supply and up to 4 kW in three-phase 380...500 V supply, the drive is supplied in a customizable enclosure suitable for ready-to-use motor starter applications. From 5.5 kW in three-phase 380...500 V supply, the drive is supplied in a standard enclosure.

The Altivar 31C drive includes an integrated terminal with display, menu scroll keys and local run and stop control keys.

It also incorporates the Modbus and CANopen industrial communication protocols as standard. It communicates on these communication buses and networks by means of a single RJ45 connector. This can be located remotely under the enclosure via an IP 55 internal cable, to be ordered separately.

The entire range complies with international standards IEC 61800-5-1, IEC 61800-2 and IEC 61800-3, UL, CSA and GOST certifications and has been developed to meet the requirements of European Directives to obtain the CE mark.

PF64280



Application: textiles

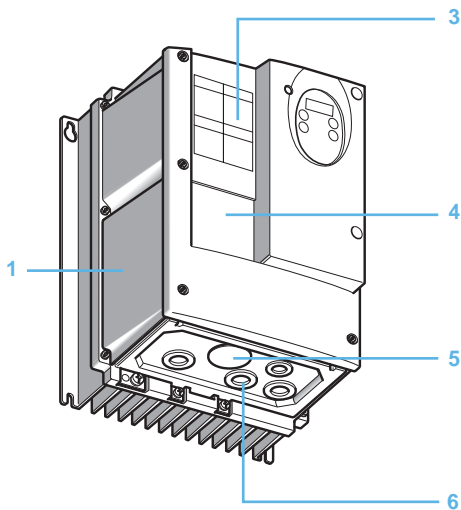

Customizable enclosure:  
ATV 31C●●M2, ATV 31C037N4...CU40N4

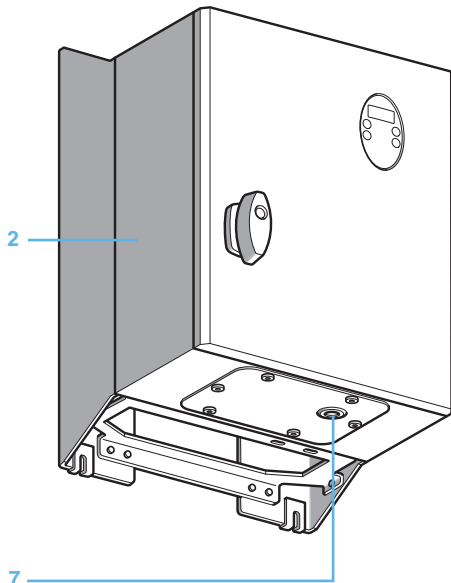

Standard enclosure:  
ATV 31CU55N4...CD15N4

### An optimized offer (continued)

#### Customizable enclosed drive (0.18 kW to 4 kW)

This range allows full customization of the human-machine interface part of the enclosure.

The IP 55 enclosure includes:

- A drive 1 with external heatsink
- Removable covers 3 to 6 for adding the following components:
  - 3: 3 buttons and/or LEDs with plastic flange (Ø 22) and 1 speed reference potentiometer
  - 4: A Vario switch disconnect or GV2 circuit-breaker
  - 5: A blanking plug for the RJ45 connector on the IP 55 internal cable
  - 6: A cable gland for cable routing

The combinations (circuit-breaker/contactor/drive) required for the motor starter function can be found on page 60449/5.

Example references:

- 3-pole Vario switch disconnect (V●● + KC●1●Z)
- Selector switch with 3 fixed positions XB5 D33
- LED XB5 AV●●
- 2.2 kΩ potentiometer, SZ1 RV1202

These references are to be ordered separately and can be found in the "Motor starter solutions. Control and protection components" and "Control and signalling components" catalogues.

These products are supplied as standard for customer assembly and wiring.

However, it is also possible to order ready-wired and connected components; please consult our Customer Care Centre.

#### Standard enclosed drive (5.5 kW to 15 kW)

The IP 55 enclosure includes:

- A drive 2 with external heatsink and fans
- A blanking plug 7 for the RJ45 connector on the IP 55 internal cable

The combinations (circuit-breaker/contactor/drive) required for the motor starter function can be found on page 60449/5.

#### Electromagnetic compatibility, EMC

The incorporation of EMC filters in Altivar 31C drives as standard simplifies installation and provides a very economical means of ensuring devices meet the criteria to receive the CE mark. If necessary, optional additional EMC filters are available.

#### External accessories and options

Various external accessories and options can be used with the Altivar 31C (1 or 2):

- Braking resistors
- Line chokes
- Additional EMC input filters
- Output filters, motor chokes and ferrite suppressors
- IP 55 cordsets with RJ45 connectors for control via Modbus serial link or CANopen machine bus

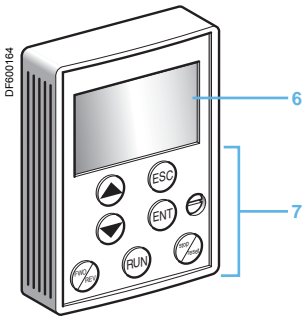
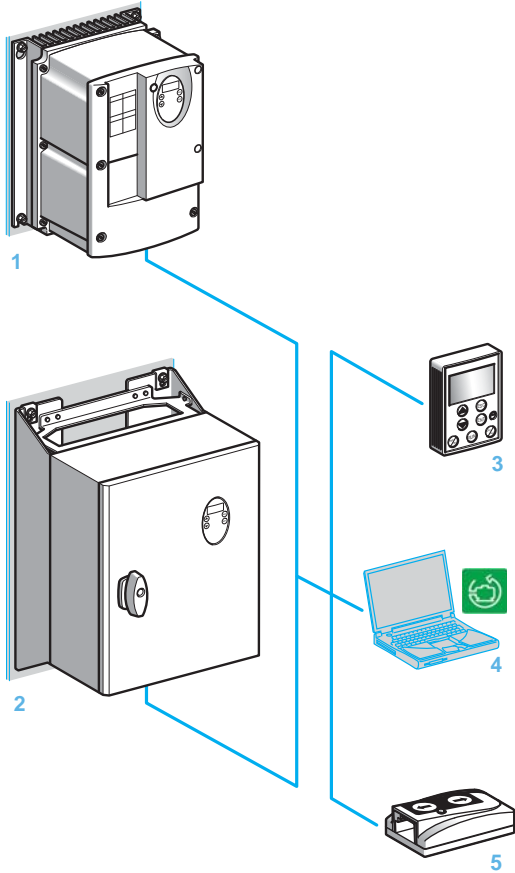

VW3 A31101

### An optimized offer (continued)

#### Dialogue options and configuration tools

Various dialogue options provide access to the Altivar 31C drive's (1 or 2) configuration, adjustment, control and signalling functions.

Options available:

- Remote display terminal 3
- SoMove setup software 4
- Simple Loader configuration tool 5

#### Remote display terminal

The remote terminal connects directly to the Altivar 31C drive.

It can be mounted on the door of an enclosure (wall-mounted or floor-standing) with IP 65 protection on the front panel.

The remote display terminal is used:

- To control, adjust and configure the drive remotely
- For visible remote signalling
- To save and download configurations; 4 configuration files can be saved.

#### Description

##### 6 Display

- 4-digit display visible at 5 m
- Display of numeric values and codes
- The display flashes when a value is stored
- The display flashes to indicate a fault on the drive

##### 7 Use of keys:

- Navigation arrows, ENT and ESC keys for settings and configurations
- FWD/REV key: Reverses the direction of rotation of the motor
- RUN key: Local control of motor operation
- STOP/RESET key: Local control of motor stopping/drive fault clearing

#### SoMove setup software

The SoMove setup software can be used to access the configuration, adjustment, debugging (using the Oscilloscope function) and maintenance functions for Schneider Electric variable speed drives and starters.

The SoMove software can also be used to customize the integrated display terminal menus.

#### Simple Loader configuration tool

The Simple Loader configuration tool enables one powered-up drive's configuration to be duplicated on another powered-up drive.

It is connected to the drive's RJ45 communication port.

### An optimized offer (continued)

#### Communication buses and networks

In addition to the Modbus serial link and CANopen machine bus which can be accessed directly, various modules can be used to connect the Altivar 31C to the following communication buses and networks:

- Modbus TCP network
- Fipio bus
- PROFIBUS DP bus
- DeviceNet network

The communication buses and networks provide access to the Altivar 31C drive's configuration, adjustment, control and monitoring functions.  
See page 60447/2.