

S3000

Safety laser scanner

GB

SICK AG • Industrial Safety Systems
 Erwin-Sick-Straße 1
 D-79183 Waldkirch • www.sick.com
 8010277/V936/2011-07-19 • RV/XX
 Printed in Germany (2011-07) • All rights reserved • Subject to change without notice

SICK
 Sensor Intelligence.

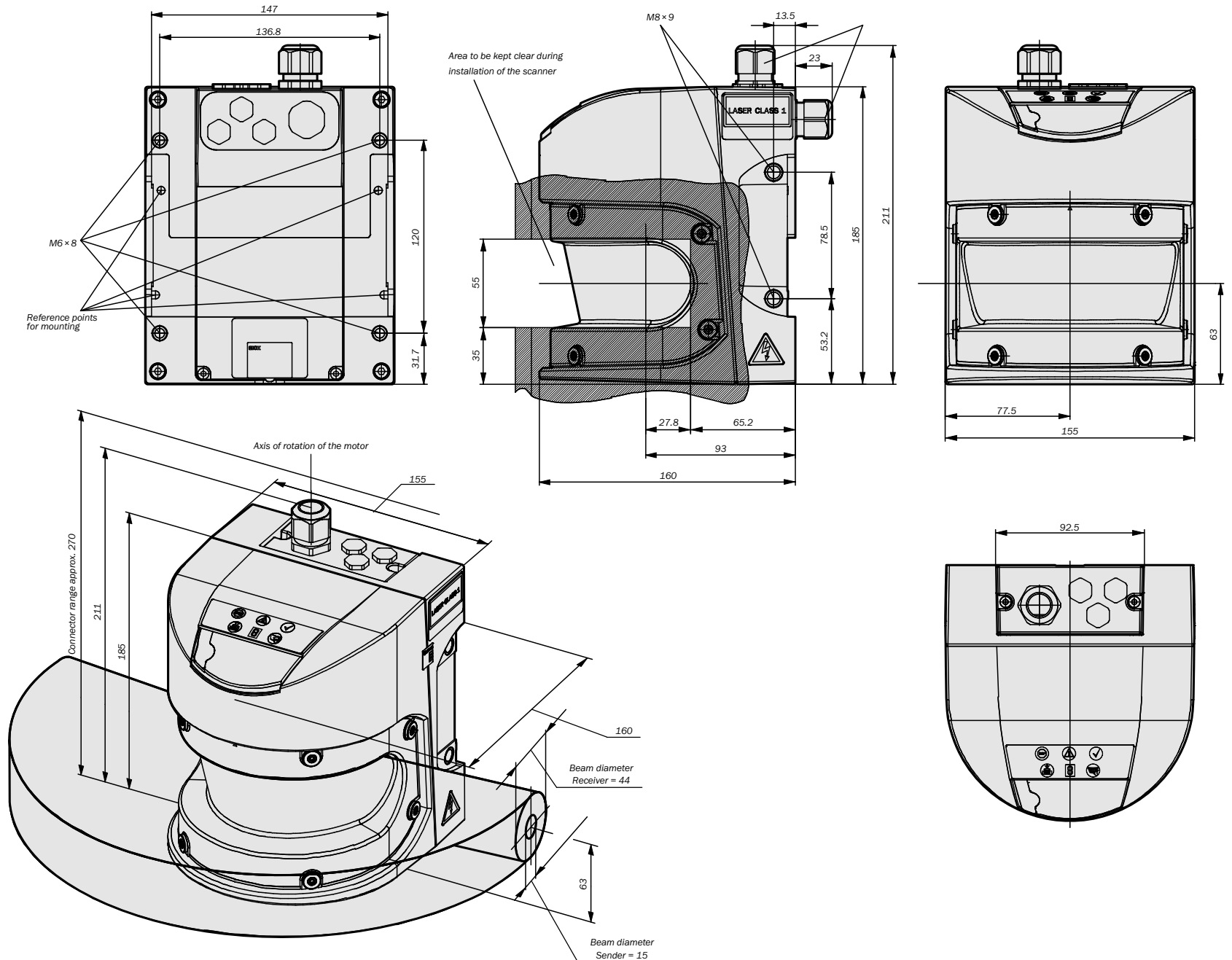

2 Mounting kits 1, 2 and 3

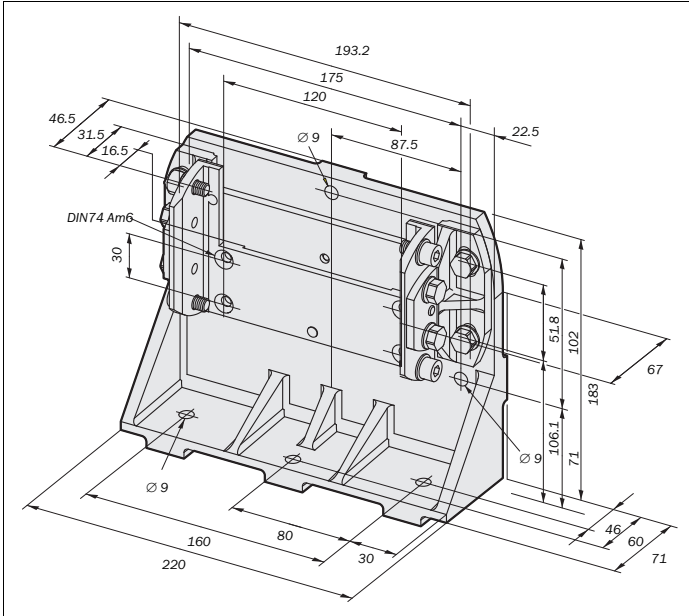

3 System connection

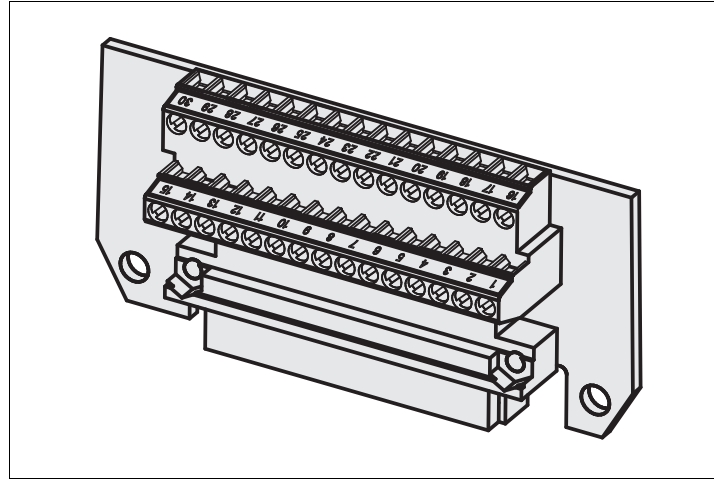

Pin	Signal	Function	Standard	Advanced	Professional	Expert	Remote
1	+24 V DC	Supply voltage S3000	■	■	■	■	■
2	0 V DC	Supply voltage S3000	■	■	■	■	■
3	OSSD1	Output signal switching device	■	■	■	■	■
4	OSSD2	Output signal switching device	■	■	■	■	■
5	RESET	Input, Reset	■	■	■	■	■
6	EDM	Input, external device monitoring	■	■	■	■	■
7	ERR/ UNI-I/01	Application diagnostic output and universal I/O or connection for a jumper for addressing as Guest ¹⁾	■	■	■	■	■
8	RES_REQ/ UNI-I/02	Output, reset required or Universal I/O	■	■	■	■	■
9	WF/ UNI-I/03	Output, object in warning field or Universal I/O	■	■	■	■	■

¹⁾ In an EFI system, a device must be defined as a Guest using a jumper between pin 7 and pin 10. This action is also necessary if several safety laser scanners are connected to one EFI string on a Flexi Soft safety controller.

Pin	Signal	Function	Standard	Advanced	Professional	Expert	Remote
10	A1	Static control input A or connection for a jumper for addressing as Guest ¹⁾	■ ²⁾	■	■	■	■ ²⁾
11	A2	Static control input A		■	■	■	
12	B1	Static control input B		■	■	■	
13	B2	Static control input B		■	■	■	
14	EFI _A	Enhanced function interface = safe SICK device communication	■	■	■	■	■
15	EFI _B		■	■	■	■	■
16	+24 V DC	Supply voltage incremental encoder 1			■	■	
17	GND				■	■	
18	C1 or INC1_0	Static control input C or dynamic control input (incremental encoder input) 1			■	■	
19	D1 or INC1_90	Static control input D or dynamic control input (incremental encoder input) 1			■	■	
20	+24 V DC	Supply voltage incremental encoder 2			■	■	
21	GND				■	■	
22	C2 or INC2_0	Static control input C or dynamic control input (incremental encoder input) 2			■	■	
23	D2 or INC2_90	Static control input D or dynamic control input (incremental encoder input) 2			■	■	
24	Reserved, do not use!						
25	RxD-	RS-422 interface for output of measured data	■	■	■	■	■
26	RxD+		■	■	■	■	■
27	TxD+		■	■	■	■	■
28	TxD-		■	■	■	■	■
29	EFI _A	Enhanced function interface = safe SICK device communication	■	■	■	■	■
30	EFI _B		■	■	■	■	■

²⁾ No control input A on S3000 Standard and Remote.